

ATLANTEK

Model 400

Thermal Response Test System

Operators Manual

Revised January 15, 2013



Notice:

The information contained in this document is subject to change without notice.

Global Media Instruments makes no warranty of any kind with regard to this material, including, but not limited to, the implied warranties of merchantability and fitness for a particular purpose. No patent liability is assumed with respect to the use of the information contained herein.

Global Media Instruments shall not be liable for errors contained herein or for incidental or consequential damages in connection with the furnishing, performance or use of this material.

All rights reserved. No part of this document may be photocopied, reproduced or translated to another language without prior written consent of **Global Media Instruments, LLC**.

Copyright ©2013 Global Media Instruments, LLC

Global Media Instruments, LLC

1075 Bee court, Milpitas, CA 95035 USA

Telephone/Fax: (408) 791-3133, Email: support@paper-testers.com

Warranty

Global Media Instruments warrants its products to be free of defects in material and workmanship under normal use conditions for a period of one (1) year commencing the date of shipment from its factory. Given notice and upon confirmation of such defects.

Global Media Instruments will, at its option, either repair or replace the defective product.

Exclusions

This warranty does not apply to defects resulting from: improper or inadequate maintenance by customer; misuse, abuse, alteration; unauthorized or improper service; operation outside the specified environmental range; improper shipping or installation; and use of unqualified media. This warranty does not apply to normal wear items such as friction pads, belts, print head and platen.

Warranty Limitations

Global Media Instruments makes no other warranty, either expressed or implied, with respect to this product. **Global Media Instruments** specifically disclaims the implied warranties of merchantability and fitness for a particular purpose. **Global Media Instruments** will not be liable for any special, indirect, incidental or consequential damages or loss, including loss of data from failure of the product. Some states or provinces do not allow limitations on the duration of an implied warranty, so the above limitations may not apply to you. However, any implied warranty of merchantability or fitness is limited to the one-year duration of this written warranty.

Table of Contents

1.0 Product Overview and Introduction

- 1.1: Basic Product Description
- 1.2: Normal Operating Procedure

2.0 Getting Started

- 2.1: Unpacking the Model 400 System
- 2.2: Starting the Model 400 System
- 2.3: Executing a Test

3.0 Basic Operation and Controls

- 3.1: Pattern Display and Push-buttons
- 3.2: Print Energy Rocker Switch
- 3.3: Pattern Repeats Rocker Switch
- 3.4: Dynamic Response Push-buttons
- 3.5: Dynamic Speed Test

4.0 Supported Test Patterns

5.0 Print Energy Settings

6.0 Print head Voltage Settings

- 6.1: Print head Voltage Setting Procedure
- 6.2: Print head Resistance to Voltage Settings Table

7.0 Mechanical Parts and Adjustments

- 7.1: Print head Lift Lever
- 7.2: Print head Pressure Adjustment
- 7.3: Print head Pivot Pin
- 7.4: Print head Positioning Thumbwheel Screw and Locking Nut

8.0 System Maintenance

- 8.1: Print head Cleaning Procedure
- 8.2: Print head Force or Pressure Check
- 8.3: Print head Wear

9.0 System Technical Specifications

10.0 Trouble Shooting Guide

11.0 Replacement Parts

1.0 Product Overview and Introduction

The **ATLANTEK** Model 400 System is a standalone, dynamic response test system that provides an easy way to perform periodic checks of direct thermal media. This Fourth Generation product is designed to be operated by non-technical personnel in manufacturing and laboratory environments.

1.1 Basic Product Description

The Model 400 System gives the User complete control over the important variables in a thermal printing system. The User can vary print speed, applied print energy and testing patterns. The user also has, at its disposal, several mechanical adjustments such as print head position and print head pressure; adjustments to allow testing of many various direct thermal receptor media.

1.2 Normal Operating Scenario

Under normal operating conditions, the operator positions a sample of direct thermal media under the thermal print head. The operator then lowers the print head onto the test sample. By selecting the appropriate switch setting on the front panel, the operator can customize the type of dynamic response test to be performed. There are three print energy/speed⁽¹⁾ settings and seven different test patterns available. Once the print energy and test pattern are defined, the operator has the option of printing a full dynamic response test or printing a single test pattern at any of the ten print energy settings. Also included in the Model 400 System is the ability to repeat print any single test pattern either once, five or ten times. For Users that are interested in investigating the effects of varying print speed while holding print energy constant⁽²⁾, a dynamic speed test is included in the standard system configuration.

⁽¹⁾ *The three print energy settings available in the Model 400 system control print speed and applied print energy. Each of the energy selections retrieves the print energy values from a fixed table of values located within the Model 400 print controller.*

⁽²⁾ *The effect of varying print speed while holding print energy constant is accomplished by setting the Pattern Display to 0 and activating one (1) of the ten (10) Dynamic Response Push-buttons.*

2.0 Getting Started

The Model 400 system should be placed on a flat surface in a well-lit area with sufficient room around the printer to gain access to all switches and mechanical adjustments. Although not mandatory, it is suggested that the Model 400 system be located in an environment where the temperature is held relatively constant at room temperature.

2.1 Unpacking the Model 400 System

Unpack and unwrap all components of the Model 400 system. Lift the thermal print head off of the platen by turning the print head lever. Remove the packing foam that is located underneath the print head. Before turning on the power, visually inspect the entire system for any physical damage that may have occurred during shipment. Also, verify that the ribbon cable and connector are securely fastened to the thermal print head. (*Loose or intermittent connections may cause severe damage to the thermal print head*). Review the packing list in order to be assured that all the necessary components of the Model 400 system have been included.

2.2 Starting the Model 400 System

Raise the print head by rotating the Print head Lift Lever its stop position. Place a sufficiently long strip of receptor media or a roll of the receptor media located at the rear of the Model 400 with the leading edge on the platen and lower the print head on the receptor media to be tested. With the print head in the down position, turn ON the AC power to the Model 400 system. The READY LED will blink while the print head is being preheated; during this time the ability to execute a test will be disabled. Typical warm-up time for the print head to come up to its target temperature is less than 5 minutes. Once the print head temperature has been elevated to the desired value the READY LED will stop flashing and appear a solid green indicating that the Model 400 is ready for use.

2.3 Executing a Test

At the initial startup, the single digit test pattern LED display will show a “1”, indicating that the current Model 400 test pattern is pattern number 1, the solid rectangle pattern. A complete description of supported test patterns can be found in Section 4.0. With a test sample loaded in the Model 400 and the READY LED illuminating a solid green, press the Dynamic Response button on the front panel. The user will observe a complete dynamic response being printed. A Model 400 dynamic response test consists of 10 image areas, each one printed at an increasing amount of print energy. On the **HIGH ENERGY** setting, a standard sensitivity direct thermal paper will show a minimal amount of imaging as the test begins but will quickly move through a transitional phase followed by a fully saturated image. The image density across the test pattern should be consistent verifying proper operation of the print head and alignment between the dot line and the print platen.

3.0 Basic Operation and Controls

The Model 400 system gives users control over the important variables that may be adjusted to optimize the performance of a thermal printing system. Adjusting mechanical settings, print energy settings or choosing an appropriate test pattern help to more closely simulate the application environment for a particular direct thermal media, ultimately leading to more reliable test results. The Model 400 offers a diverse set of controls for users to customize specific test sessions based on application or media characteristics.

3.1 Pattern Display and Push-buttons

On the front panel of the Model 400, in the lower left side, there is a single digit display and a push-button to the right side of it that allows the User to scroll through the different print patterns that are programmed into the Model 400. The display can be scrolled from 0 through 7. See 4.0 for the Supported Print Patterns.

3.2 Print Energy Rocker Switch

On the front panel of the Model 400, in the middle left side, there is a three position switch labeled Energy. This switch enables the User to set one of three levels of Print Energy, that is Low, Medium and High. See 5.0 for Print Energy Settings and Densities.

3.3 Pattern Repeats Rocker Switch

On the front panel of the Model 400, in the upper left side, there is another three position switch labeled Repeat. This switch enables the User to select either one single print of a specific Pattern at one Dynamic Response level or the User can select five or ten continuous prints of one specific Pattern at one Dynamic Response level.

3.4 Dynamic Response Push-buttons

On the front panel of the Model 400, on the right side, there are a set of 10 switches labeled 1 through 10 and one push-button below used for full Dynamic Response. The switches labeled 1 through 10 indicate the 10 levels of Dynamic Response, going from a minimum level at 1 through the maximum level at 10; these are used to print a pattern at a single level of Dynamic Response. Pressing the one bottom push-button for Dynamic Response allows a pattern to be printed at all 10 levels of Energy or Density.

3.5 Dynamic Speed Test

For the User interested in the effects of varying the print speed for a constant print energy, a Dynamic Speed Test is included in the standard System configuration. The User must select Pattern zero (0) using the Pattern Display Push-button. The User can then press one of the Dynamic Response Push-buttons; a ten (10) speed step repeats of a picket fence Barcode will be printed. The speeds at which the Barcode is printed will be determined by the selection of either Low, Medium or High Energy levels.

4.0 Supported Test Patterns

The following are the Model 400 System supported test patterns. See section 3.0, 3.1, 3.2, 3.3 and 3.4 for Control Operation and Function.

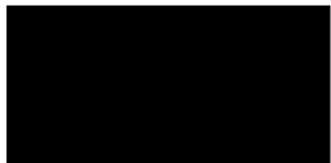

Pattern 1

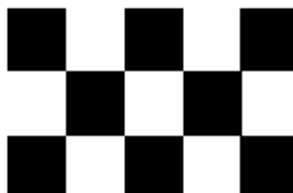

Pattern 2



Pattern 3



Pattern 4

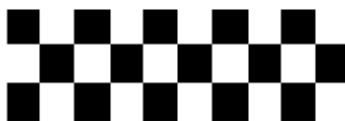

Pattern 5



Pattern 6

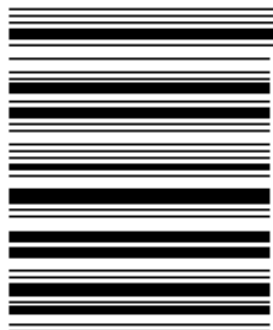

Pattern 7

5.0 Print Energy Settings

The following is information related to the Print head geometry, the Dynamic response levels (1 through 10), with corresponding Print head pulse time (Ton) and applied Energy (mj).

Dot Pitch (mm): 0.0833
Print head Dot Size (mm): Width: 0.0683 Length: 0.084
Print head Dot Area (mm²): 0.0057372

Applied Print head Power (w/dot): 0.445

High Energy Setting (1.0 ips, Tcyc = 3.28 msec)

Section	Ton (msec)	Energy (mj)	Energy Density (mj/mm ²)
1	0.0420	0.0187	3.254
2	0.0806	0.0359	6.250
3	0.1187	0.0528	9.209
4	0.1569	0.0698	12.167
5	0.1955	0.0870	15.163
6	0.2336	0.1040	18.121
7	0.2718	0.1209	21.080
8	0.3102	0.1380	24.057
9	0.3485	0.1551	27.034
10	0.3867	0.1721	29.993

Med. Energy Setting (4.0 ips, Tcyc = 0.820 msec)

Section	Ton (msec)	Energy (mj)	Energy Density (mj/mm ²)
1	0.0415	0.0185	3.217
2	0.0596	0.0265	4.623
3	0.0782	0.0348	6.065
4	0.0966	0.0430	7.489
5	0.1144	0.0509	8.876
6	0.1330	0.0592	10.318
7	0.1514	0.0674	11.742
8	0.1697	0.0755	13.166
9	0.1879	0.0836	14.571
10	0.2062	0.0918	15.995

Low Energy Setting (10.0 ips, Tcyc = 0.328 msec)

Section	Ton (msec)	Energy (mj)	Energy Density (mj/mm ²)
1	0.0386	0.0172	2.996
2	0.0515	0.0229	3.994
3	0.0644	0.0286	4.993
4	0.0775	0.0345	6.010
5	0.0904	0.0402	7.008
6	0.1032	0.0459	8.007
7	0.1161	0.0517	9.005
8	0.1290	0.0574	10.004
9	0.1418	0.0631	11.002
10	0.1547	0.0689	12.001

6.0 Print head Voltage Settings

In the event that a Print head needs to be replaced, the following table (in 6.2) is to be used for setting the voltage to the Print head, to ensure proper operating point for the new Print head.

6.1 Print head Voltage Setting Procedure

Remove the left side/top cover from the Model 400 System. There are six (6) screws holding the left side/top cover in place; three (3) in the front plate and three (3) in the rear plate located at the top and side of each plate. This will expose the Controller board on the left side of the Model 400 System and the system Power Supply, located on the rear of the Controller assembly. **A Digital Voltmeter set on the DC scale is needed to set the Print head voltage or Vset.**

Clip the negative lead of the DVM to the Controller board at Test Point 3 (TP3, GND) located in the upper left hand corner. Clip the positive lead of the DVM to the Controller board at Test Point 1 (TP1) located approximately four (4) inches to the right of TP3. The resistance of the Print head is marked on the Print head and should be noted before installation. Ensure that the ribbon cable is properly attached to the Print head. Turn on the Power to the Model 400 System. Observe the reading on the DVM. Using the following table, match the proper Phr (Print head Resistance) with its appropriate Vi (Power Supply Voltage)Vset. To adjust this voltage, there is a Potentiometer located at the upper right side of the Power Supply in the rear of the Controller board. The setting of this voltage should be within the tolerance of +/- 0.035 Volts.

6.2 Print head Resistance to Voltage Settings Table (revised May 2003)

Phr = Print head Resistance
Vi = Power Supply Voltage

<u>Phr (Ohm)</u>	<u>Vi (Volt)</u>	<u>Phr (Ohm)</u>	<u>Vi (Volt)</u>	<u>Phr (Ohm)</u>	<u>Vi (Volt)</u>
1050	21.92	1190	23.30	1330	24.60
1055	21.97	1195	23.35	1335	24.65
1060	22.02	1200	23.39	1340	24.69
1065	22.08	1205	23.44	1345	24.74
1070	22.12	1210	23.49	1350	24.78
1075	22.17	1215	23.54	1355	24.83
1080	22.22	1220	23.58	1360	24.87
1085	22.27	1225	23.63	1365	24.92
1090	22.32	1230	23.68	1370	24.96
1095	22.37	1235	23.73	1375	25.01
1100	22.42	1240	23.77	1380	25.05
1105	22.47	1245	23.82	1385	25.10
1110	22.52	1250	23.87	1390	25.14
1115	22.57	1255	23.93	1395	25.19
1120	22.62	1260	23.96	1400	25.23
1125	22.67	1265	24.01	1405	25.27
1130	22.72	1270	24.05	1410	25.31
1135	22.77	1275	24.10	1415	25.36
1140	22.81	1280	24.14	1420	25.40
1145	22.86	1285	24.19	1425	25.45
1150	22.91	1290	24.24	1430	25.49
1155	22.96	1295	24.29	1435	25.54
1160	23.01	1300	24.33	1440	25.58
1165	23.06	1305	24.38	1445	25.62
1170	23.11	1310	24.42	1450	25.66
1175	23.16	1315	24.47	1455	25.71
1180	23.20	1320	24.51	1460	25.75
1185	23.25	1325	24.55		

7.0 Mechanical Parts and Adjustments

The following are mechanisms that provide the User either normal operation usage or allow for adjustment or refinement of mechanical settings such as pressure and alignment for both operation and maintenance. **Refer to Figure 1 for Mechanism locations.**

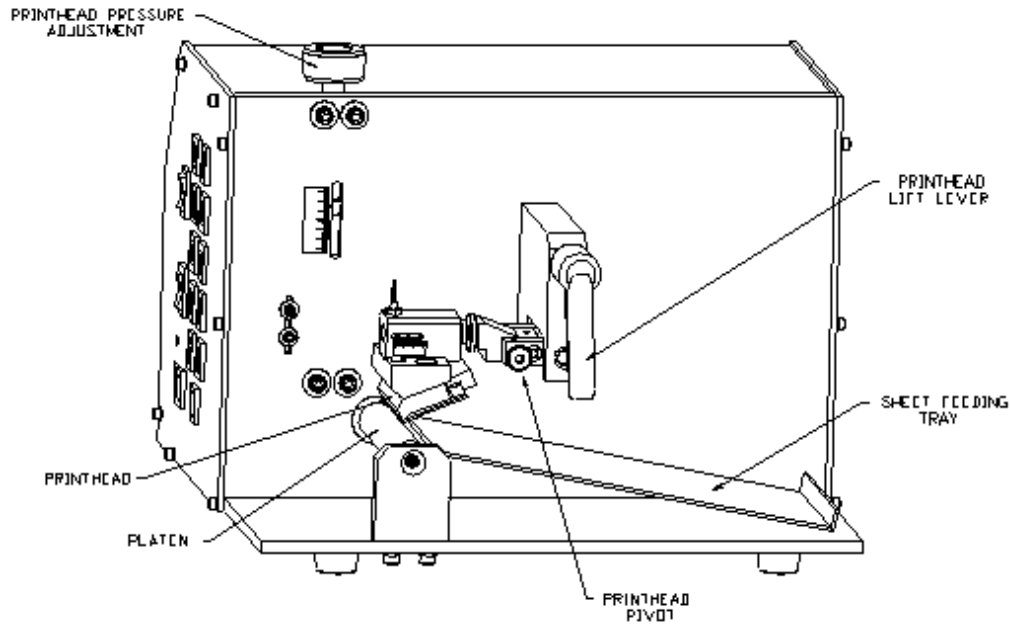

Figure 1

7.1 Print head Lift Lever

The Print head Lift Lever allows for the raising and lowering of the Print head. **The Print head should always be raised when the Model 400 System is not in use.** The Print head can be lowered by turning the Print head Lift Lever in a clockwise rotation completely until it come to a firm stop. The Print head is raised by turning the Print head Lift Lever in a counter-clockwise direction.

7.2 Print head Pressure Adjustment

The Print head Pressure Adjustment allows the User to change the lineal force on the Print head over the entire Platen. This adjustment is factory set for 3.0 pounds. Due to receptor media thicknesses and coatings and test criteria, it may be necessary to adjust the Print head pressure. It is recommended that excessive force or pressure not be used as it will cause increased abrasive wear on the Print head and possibly deform the Platen.

7.3 Print head Pivot Pin

The Print head Pivot Pin allows for the raising of the Print head away from the Platen for cleaning and maintenance. The Print head must be in its up position to do this. Hold the sides of the Print head holding block with two fingers of one hand; this is done to keep the Print head from falling on the Platen when the Pivot Pin is released. To release the Pivot Pin, pull gently on the knurled knob and the Pivot Pin will slide out of the elongated cavity, allowing the Print head to float and be put in its raised position. Lift the Print head up and back and apply a small amount of inward pressure on the knurled knob. When the Print head is raised to the proper height, the Pivot Pin will slide into its “IN” position and lock the Print head in its up position. To lower the Print head back into its working position, hold the sides of the Print head holding block, pull gently on the knurled knob and the Pivot Pin will slide out allowing the Print head to float and be returned to its original position.

7.4 Print head Positioning Thumbwheel Screw and Locking Nut

This adjustment should not have to be adjusted unless there is a significant difference in receptor media thickness or if a Print head is replaced. This adjustment is for setting the tangential positioning of the Print head dot line with the Platen for best quality prints across the width of the Print head. If re-positioning needs to be made, unlock the locking nut just forward of the knurled Positioning Thumbwheel. Rotating or turning the knurled Positioning Thumbwheel will allow the Print head to move forwards or backwards to be positioned tangent to the Platen. It may be necessary to test a printed pattern and make a minor re-adjustment to obtain good quality across the entire width of the Print head. Lock the locking nut in place to keep the Print head positioned in its optimum location.

8.0 System Maintenance

The only maintenance required is that the Print head and Platen be inspected and cleaned on a regular basis. Depending on usage, the Print head should be cleaned regularly to remove debris and other build up that may accumulate along the dot line that could ultimately affect test results and print head life. The Platen should be inspected for a build up of debris, pitted marks or wear that will alter test results and cause un-even wear on the Print head.

8.1 Print head Cleaning Procedure

The following steps should be used to clean the Print head. Turn off POWER to the Model 400 System. Lift the Print head to the unload position by engaging the PRINTHEAD LIFT LEVER. Place a piece of cloth or heavy paper on the Platen to avoid alcohol spills on the Platen. When unloaded, the Print head should pivot freely about the mounting screw. Pull the Print head Lift Pin on the PRINTHEAD PIVOT and lift the Print head. When the Print head pivot block has been fully raised, the head lift pin may be pushed in holding the Print head in an UP position, exposing the dot line for cleaning and observation. Acetone, Methanol and/or Isopropyl Alcohol applied to a swab or Q-tip should be used to clean the print head.

8.2 Print head Force or Pressure Check

Periodically the Print head force or pressure should be verified. This measurement can easily be done by hooking force dial in the eyelet located above the dot line on the Print head mounting block. With a strip of paper loaded in the Model 400, and the Print head in the down position, lift up on the force dial until the paper sample moves freely. The force should be measured at between 2.5 and 3.5 pounds.

The Print head force is factory set at 3.0 pounds to give optimal pressure of about 1.0 pounds per lineal inch over the Print head. Increasing or decreasing the Print head force is done by turning a screw on the PRINT HEAD PRESSURE ADJUSTMENT to compress the spring assembly. Increasing the force over the recommended pressure will cause faster wear on the Print head and should be avoided.

8.3 Print head Wear

Depending on testing and usage, the thermal Printhead's resistance should be verified that it is within the manufacturer's specifications. Over time, the heater elements resistance can change because of chemical contamination, electrical over stressing or abrasive wear.

With normal usage the print head should be verified every six months. Contact Global Media Instruments about print head resistance verification.

A method to calibrate or estimate the Model 400 System is to retain an original printed sample and an unimaged supply of a readily available grade of direct thermal media.

Periodically compare a recent sample of this paper, imaged in the Model 400 system, against the original test sample; if significant differences in optical density exist, then the Printhead's heater elements may have changed resistance and the print head should be

verified. Note that the long-term stability of the original test sample must be considered when comparing to a newly-printed image.

9.0 System Technical Specifications

Printing Method	Direct Thermal
Print Resolution	300 dpi
Image Width	53 mm
Sample Width	100 mm
Print head Construction	Thin Film
Print head Type	Corner Type
Print Speed	3 Programmable Settings, 10 ips Maximum
Mechanical Adjustments	Print head Pressure Print head Position
Host Computer Interface	<i>(Only on obsolete product versions)</i> Serial (RS-232)
Power Requirements	115v 60 Hz/ 220v 50Hz
Test Patterns	Checkerboard, Solid, Barcode (UPCA),
Test Selection	Dynamic Response (10 Print Sections), Any Print Section can be selected and printed Individually. Any test section can be repeated 1, 5 or 10 times

10.0 Trouble Shooting Guide

Any service technician can easily maintain the Model 400 system without any factory training. The Model 400 Dynamic Response Tester is a robust system. However, if a problem occurs, use the following guide to diagnose potential system problems.

Problem: Ready LED blinks continuously after power-up.

Remedy: At power-up the substrate of the Print head is preheated to be assured of a constant operating baseline for testing. Normal preheat time after power-up is 10-12 minutes. If the LED continues beyond this time verify the connections to the print head.

Problem: The Ready LED blinks when the print button is pressed.

Remedy: If the print head is in the unloaded, or UP position the control electronics will not allow a test session to take place. **Firing print head heating elements into open air, or against the print platen may severely damage the print head.**

Problem: Printed image is light or uneven across the printhead's dot line.

Remedy: The position of the heating elements relative to the apex of the platen is adjustable by turning the thumbwheel screw at the rear of the print head assembly. This adjustment is made at the factory and should not need adjustment unless the print head is removed and the thumb screw position changed. Also, verify the applied print head force using a force dial.

11.0 Replacement Parts

Any service technician can easily maintain the Model 400 system without any factory training. Every effort is made to keep replacement parts in stock but because of unpredictable demand there are no guarantees of factory inventory. A list of the recommended spare parts for the ATLANTEK Model 400 system is listed below.

Part Number Description

837057 Replacement Model 400 Thermal Print head

203692 Model 400 Print Platen